

# PRODUCT INFORMATION PACKET

Model No: 256TTFL16042

Catalog No: U354A

20 HP Close-Coupled Pump Motor, 3 phase, 1800 RPM, 230/460 V, 256JM Frame, TEFC  
JM Motors



### Nameplate Specifications

Output HP	20 Hp	Output KW	14.9 kW
Frequency	60 Hz	Voltage	230/460 V
Current	48.0/24.1 A	Speed	1775 rpm
Service Factor	1.15	Phase	3
Efficiency	93 %	Power Factor	84
Duty	Continuous	Insulation Class	F
Design Code	B	KVA Code	G
Frame	256JM	Enclosure	Totally Enclosed Fan Cooled
Thermal Protection	No	Ambient Temperature	40 °C
Drive End Bearing Size	6309	Opp Drive End Bearing Size	6208
UL	Recognized	CSA	Y
CE	Y	IP Code	43

### Technical Specifications

Electrical Type	Squirrel Cage Induction Run	Starting Method	Across The Line
Poles	4	Rotation	Reversible
Resistance Main	.474 Ohms	Mounting	Rigid Base
Motor Orientation	Horizontal	Drive End Bearing	Ball
Opp Drive End Bearing	Ball	Frame Material	Aluminum
Shaft Type	JM	Overall Length	27.27 in
Frame Length	13.75 in	Shaft Diameter	1.750 in
Shaft Extension	5.25 in	Assembly/Box Mounting	F1/F2 CAPABLE
Outline Drawing	B-SS321151-1375	Connection Drawing	A-EE7308

This is an uncontrolled document once printed or downloaded and is subject to change without notice. Date Created:03/11/2020

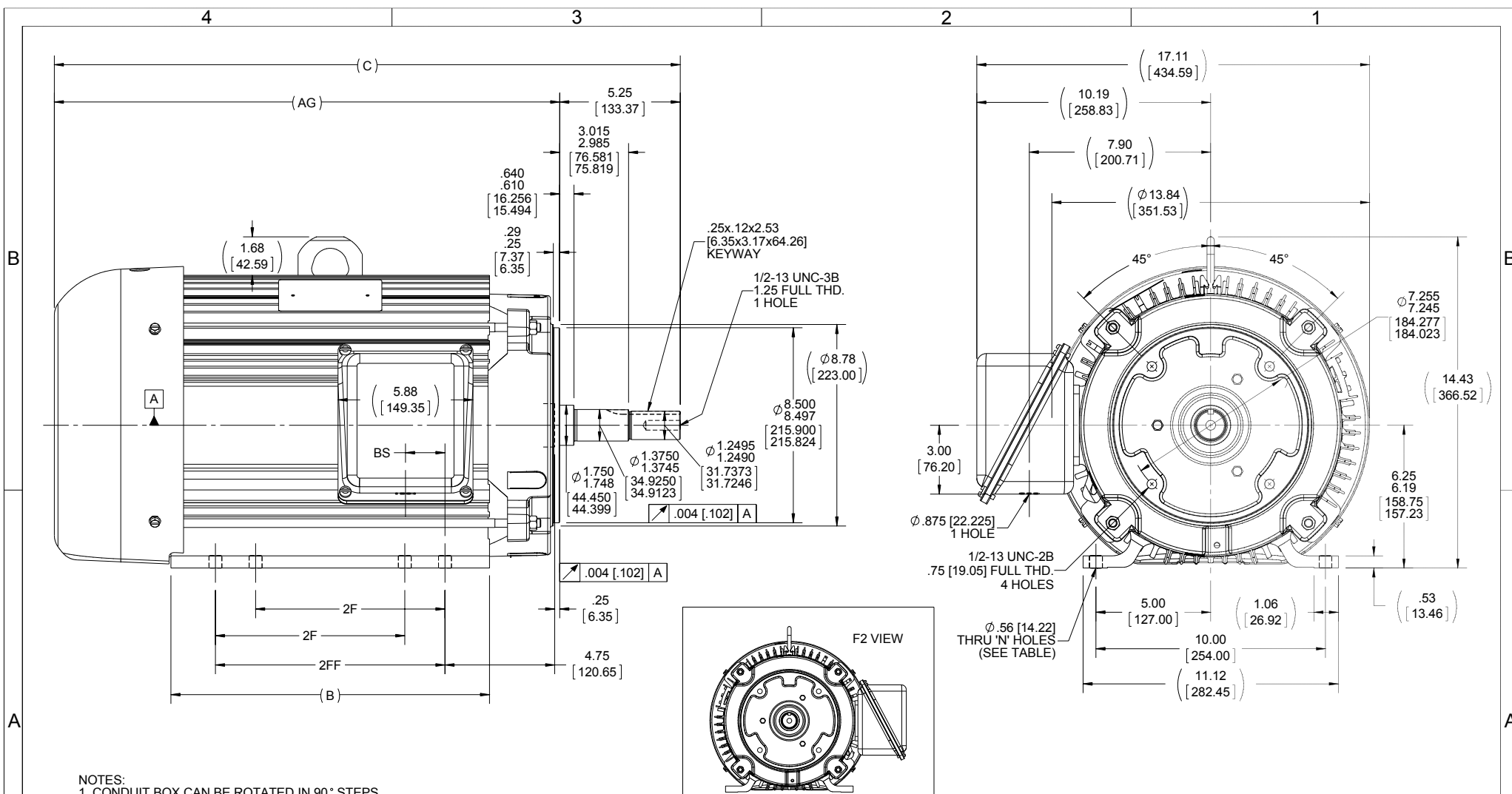

- NOTES:  
 1. CONDUIT BOX CAN BE ROTATED IN 90° STEPS.  
 2. CONDUIT BOX CAN BE MOUNTED ON OPPOSITE SIDE BY REMOVING BRACKETS AND TURNING FRAME 180°.  
 3. NAMEPLATES READ FROM CONDUIT BOX SIDE OF MOTOR.

1200	254JM	25.52 [648.21]	20.27 [514.86]	12.13 [308.10]	---	8.25 [209.55]	1.73 [43.94]	4
1375	254/256JM	27.27 [692.62]	22.02 [559.26]	13.88 [352.55]	8.25 [209.55]	10.00 [254.00]	1.73 [43.94]	8
DASH	FRAME	C	AG	B	2F	2FF	BS	N

DRAWING REVISION D	REVISION BY MSG	DATE 11-18-2015
ECO ECO-0088803	APPROVED BY TVUE	DATE 11-18-2015
ECO DESCRIPTION UPDATED TO CURRENT STANDARDS		
<small>COPYRIGHT REGAL BELOIT AMERICA, INC. ALL RIGHTS RESERVED.                  PROPRIETARY AND CONFIDENTIAL INFORMATION - THIS DOCUMENT IS THE PROPERTY OF                  REGAL BELOIT AMERICA, INC. ("OWNER") AND CONTAINS OWNER'S PROPRIETARY                  INFORMATION. ANY PERSON, CORPORATION OR OTHER FIRM RECEIVING IT IS DEEMED,                  BY RECEIVING IT, TO AGREE THAT IT, AND/OR ANY PART OF IT, SHALL NOT BE DISCLOSED                  TO ANY PERSON, CORPORATION OR OTHER ENTITY, DUPLICATED, AND/OR USED, EXCEPT                  AS EXPRESSLY APPROVED IN WRITING IN ADVANCE BY OWNER. THIS DOCUMENT SHALL                  BE RETURNED TO OWNER UPON REQUEST. IT MAY BE SUBJECT TO CERTAIN                  RESTRICTIONS UNDER APPLICABLE EXPORT CONTROL LAWS AND REGULATIONS.</small>		

TOLERANCES UNLESS OTHERWISE SPECIFIED:		
DEC.	INCH	mm
.X	+0.1	[+2.5]
.XX	+0.03	[+0.76]
.XXX	+0.005	[+0.127]
.XXXX	+0.0005	[+0.0127]
REMOVE BURRS & BREAK SHARP EDGES: .003/.015 [076/381] X 45°		
CORNER FILLETS: R.02 [51]		
MACHINED SURFACES: 200 $\sqrt{\text{mm}}$ 5.1 $\sqrt{\text{INCH}}$		
mm SHOWN IN [BRACKETS]		

DRAWN BY RWR
DATE 07-10-2007
APPROVED BY ML
DATE 07-11-2007
REFERENCE
THIRD ANGLE PROJECTION

Regal Beloit America, Inc.	
DESCRIPTION <b>OUTLINE</b> 250 JM FR. - TEFC - ALUMINUM FRAME	
MATERIAL B	PROCESS/FINISH
SIZE B	DRAWING NUMBER SS321151
SHEET 1 OF 1	



NO.	REVISION	BY & DATE	CHK	ANG	TOLERANCES UNLESS SPECIFIED		FINISH	DRAWN RM 11/20/1990				
					DEC.	INCHES						
5	CHG TO REGAL LOGO	SL 09/10/2015	AB					CHK ML 11/21/1990				
4	REVISED IEC NOTATIONS	MSG 11/15/2011	CMN	.X	±.1			APPD SAS 04/24/2003				
3	ADDED IEC NOTATIONS... (U1), (V1) ETC. MU95194	MSG 5/10/2010	MJS	.XX	±.02			SCALE 1=1				
2	ADDED THE OPTIONAL CORD CONNECTION MU46318	RDH 04/24/2003	DRS	.XXX	±.005		TITLE CONNECTION DIAGRAM 3Ø - DUAL VOLTAGE MOTOR	REF				
1	REDRAWN	RM 11/20/1990		.XXXX	±.0005		MAT'L.	FMF				
					±7'30"			PREV				
THIS DRAWING IN DESIGN AND DETAIL IS OUR PROPERTY AND MUST NOT BE USED EXCEPT IN CONNECTION WITH OUR WORK ALL RIGHTS OF DESIGN AND INVENTION ARE RESERVED THIS IS AN ELECTRONICALLY GENERATED DOCUMENT - DO NOT SCALE THIS PRINT							RFP	CAD FILE ee7308	SIZE A	DRAWING NO. EE7308	PAGE OF 5	REV. 5
							DIST WP					



P.O. BOX 8003  
WAUSAU, WI 54401-8003  
PH. 715-675-3311

DATA VOLTS: 460

CERTIFICATION DATA SHEET

CUSTOMER P.O. #:   
 ORDER #: A-EE7308   
 REFERENCE MODEL #: 256TTL16042   
 CONN. DIAGRAM: B-SS921151-1375   
 CAT #: U354A   
 OUTLINE: K2564164 R26 6   
 CUSTOMER PART #:   
 WINDING: K2564164   
 MOUNTING: F1/F2 CAPABLE   
 SPEED:   
 TYPICAL MOTOR PERFORMANCE DATA

HP	KW	SYNC RPM	FL RPM	FRAME	ENCLOSURE	TYPE	KVA CODE	DESIGN
20	14.9	1800	1775	256JM	TEFC	TEY	G	B

PH	HZ	VOLTS	AMPS	START TYPE	DUTY	INSL	S.F.	AMB	ELEV.
3	60/50	230/460#190/380	48/24.1&44/22	ACROSS-THE LINE	CONT	F	1.15	40	3300
	F.L. EFF	93.0	3/4 LD EFF	93.6	1/2 LD EFF	93.0	GTD EFF	ELECT. TYPE	
	F.L. PF	84.0	3/4 LD PF	81.0	1/2 LD PF	72.0	92.4	SQ CAGE IND RUN	

F.L. TORQUE	LR AMPS @ 460 V	L.R. TORQUE	B.D. TORQUE	F.L. RISE (°C)
59.2 LB-FT	138	104 LB-FT	146 LB-FT	247%
@ 3 FT.	POWER	ROTOR WK <sup>2</sup>	MAX. LOAD WK <sup>2</sup>	SAFE STALL TIME
65 DBA	74 DBA	3.2 LB-FT <sup>2</sup>	125 LB-FT <sup>2</sup>	25 SEC.
				START/SHOUR
				2
				MOTOR WGT
				425 LB.

\*\*\* SUPPLEMENTAL INFORMATION \*\*\*

DE BRACKET TYPE	ODE BRACKET TYPE	MOUNT TYPE	MOTOR ORIENTATION	SEVERE DUTY	HAZARDOUS LOCATION	DRIP COVER	SCREENS	PAINT
C-FACE	STANDARD	RIGID	HORIZONTAL	NO	NONE	NO	NONE	BLUE (ENAMEL)

BEARINGS	GREASE	SHAFT TYPE	SPECIAL DE	SPECIAL ODE	SHAFT	MATERIAL	FRAME MATERIAL
DE BALL 6309	POLYREX EM	JM	NONE	NONE	1045 HOT ROLLED (C-204)		ALUMINUM

THERMOSTATS	PROTECTORS	WDG RTD's	BRG RTD's	THERMISTORS	CONTROL	SPACE HEATERS
NONE	NOT	NONE	NONE	NONE	FALSE	NA

R1 (ohms/ph)	R2 (ohms/ph)	X1 (ohms/ph)	X2 (ohms/ph)	Xm (ohms/ph)	VIBRATION (in/sec)	FLOAT
0.267	0.207	0.99	1.491	28.4	0.150	ODE

* N		INVERTER TORQUE: NONE	
O		INV. HP SPEED RANGE: NONE	
T		ENCODER: NONE	
E		BRAKE: NONE	
S		FT-LB: NONE	
.		VOLTAGE: NONE	
		HZ: NONE	

PREPARED BY: FAREEDA DUDEKULA  
 DATE: 9/17/2018  
 FORM: 3531 REV 4 2/27/06  
 UL: V-INS, CONST UL REC

